

TECHNICAL DATA SHEET

B9000 60-80-100-125-160 kVA

GENERAL INFORMATION

POWER	kVA	60	80	100	125	160
UPS type		ON LINE – Double Conversion ECO MODE - Stand by (selectable)				
Nominal output power (Cos Ø 0,8)	kVA	60	80	100	125	160
Nominal output power (Cos Ø 1,0)	kW	48	64	80	100	128
Efficiency (AC ÷ AC) (ON LINE - Double Conversion)	%	> 93				
Efficiency (AC ÷ AC) (Eco Mode)	%	> 98				
Heat dissipation at nominal load and voltage	kW	3.8	4.8	6,0	7,5	9,6
	kcal/h (x1000)	3.3	4.2	5,2	6,5	8,3
UPS ambient temperature	°C	0 ÷ 40				
BATTERY ambient temperature	°C	0 ÷ +25				
UPS storage temperature	°C	-10 ÷ +70				
BATTERY storage temperature	°C	-10 ÷ +60				
Relative humidity (non condensing)	%	< 95				
Altitude	m	< 1000 (above sea level)				
Power derating for altitude > 1000 m		According "IEC EN 62040-3" According to "IEC62040-3", max 2000 m with 1% derating for +100m				
Ventilation		Forced				
Requested cooling air volume	m ³ /h	1600	1800	2100	2300	2500
Audible noise level (according EN 50091)	dB	< 60				
Standard battery type lead acid	n° cells	300				
Protection degree		IP 20				
Electromagnetic compatibility EMI		According "EN 62040-2" (CE marking)				
Safety		IEC EN 62040-1-1				
Test and performances		IEC EN 62040-3				
Paint		RAL 7035				
Accessibility		Front and top access for service				
Installation		Also against wall and/or side-by-side				
Dimensions	mm	W = 815 D = 825 H = 1670				
Weights (without battery)	kg	570	600	630	662	720
Static load (without battery)	kg/m ²	948	998	1048	1101	1198

Rev.	Descrizione / Description	Data / Date	Comp. / Comp.	Contr. / Check.	Appr. / Approv.	Lingua / Lang.	Pag. / Pag.	di Pag. / of Pag.
A	V Revision JSD409481	07.06.07	P. Conti	E. Simoni	E. Simoni	E	1	11
B	V Revision JSE410256	17.01.08	P. Conti	E. Simoni	E. Simoni	Cod. / Code		
C	V Revision JSE410524	09.0.08	P. Conti	E. Simoni	E. Simoni	JUD407774		

Input/Output cable connection		Bottom Side (Top Side on Request)
Transport		Base provided for forklift handling
Transport mechanical stress		According to "IEC62040-3"
Design standard		"IEC EN 62040" "ISO 9000:2000"
Free contact interface		Optional
Serial communication interface		Standard: RS232 - USB Optional: RS485 (ModBus protocol)
Parallel configuration (optional)		Up to 5+1 (redundant parallel) Up to 6 (power parallel)

BLOCK DIAGRAM

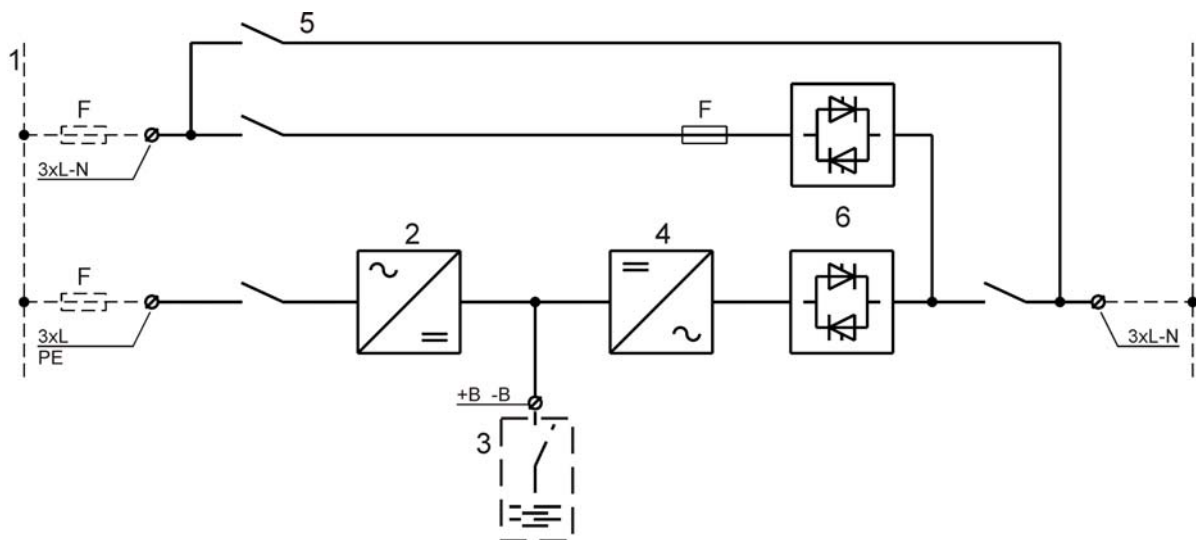

1. Input mains (separate for by-pass and rectifier)
2. Rectifier and battery charger
3. External battery
4. Inverter
5. Emergency line (by-pass)
6. Inverter (SSI) and by-pass (SSB) static switch

DESCRIPTION:

- The UPS is designed following the criteria of low environmental impact.
- The quantity of the raw material used on the magnetic components and the number of semiconductors is minimized by the means of very advanced design criteria.
- The high overall efficiency minimizes the power consumption. The high efficiency and input power factor reduces the costs during the normal operation of the UPS.
- The inverter transformer prevents the direct feed-through of the battery potential into the critical load and provides a very high rejection ratio of the power supply disturbances (spikes, surges etc.).
- The UPS is equipped with a built in very advanced self diagnostic program indicating the problems and suggesting to the service people how to repair the faults.
- The unit input power factor and the low harmonic level of the input current (THDi < 3 %) allows reduction of the dimensions and costs of the installation in terms of size of the cables and the circuit breakers. Additionally, these features prevent oversizing generator sets installed upstream.
- Eco-mode function can be set. In this intelligent mode, the mains line is continuously being monitored in order to supply with high reliability the load by the same line. If the line is downgraded and required to be conditioned, inverter takes care of the load in less than 4 msec. Once the load is accessed to properly operate in this way, in Eco-mode efficiency is considerably increased, allowing high energy saving.

UPS INPUT: RECTIFIER and BATTERY CHARGER

POWER	kVA	60	80	100	125	160
Input		Triphase				
Nominal input voltage	Vac	400				
Range	%	-20/+10				
Input frequency	Hz	50 - 60				
Range	Hz	±5				
Input power factor		> 0.99				
Input current THDi	%	< 3				
DC output voltage accuracy	%	±1				
Walk-in time duration	s	10				
DC output voltage ripple	% rms	1				
Battery recharging characteristic		IU (DIN 41773)				
Temperature voltage compensation		Optional				
Boost charge function (NiCd or Lead Open Battery)		Configurable				
Maximum recharging current						
- at nominal load	A	15	15	15	20	20
- with DCM function (max current)	A	50	50	100	100	100
AC-DC converter type		PFC IGBT				
Input protection		Fuses				
Nominal current absorbed from mains (at nominal load and battery charged)	A	75	100	125	156	200
Maximum current absorbed from mains (at nom. load and max. recharging current)	A	94	126	157	196	252

DESCRIPTION:

- The Input rectifier is designed to minimize the current harmonics rejected back into the input mains.
- The technology is based on a 6-IGBT matrix PFC, fully digitally controlled by a last generation 32 bit microcontroller.
- Large input mains variations are allowed without affecting the battery charge condition.
- The battery charge function is built into the same converter.
- The converter is designed to recharge the battery for extended time autonomies.
- By means of the DCM (Dynamic Charging Mode) function, very long autonomy time batteries can be achieved without increasing total charging time. It is achieved further increasing the maximum battery charge current, without the whole inverter power being drawn by the load.

BATTERY

POWER	kVA	60	80	100	125	160
Type (standard) other on request		Lead Sealed Free maintenance				
Number of Cells		300				
Floating voltage at 25°C		680				
Minimum discharge voltage		496				
Power requested by inverter (At nominal Load)	kW	50	68	84	105	135
Curr. req. from inverter (nominal load-minimum Vdc)	A	102	136	170	212	272
Battery Protection (external to the UPS)		Wall mounted fuse box on request				
Battery Test		Included as standard				

DESCRIPTION:

- The standard battery is composed of 300 sealed lead cells.
- The boost charge is available as an option for other battery types.
- Generator set mode available.
- The battery temperature compensation is available as an option.
- Long autonomy batteries can be used.
- Periodical automatic battery test available with adjustable time.

UPS OUTPUT: INVERTER

POWER	kVA	60	80	100	125	160
Inverter Bridge		IGBT (High Frequency Comm.)				
Nominal output power (Cos Ø 0,8)	kVA	60	80	100	125	160
Nominal output power (Cos Ø 1,0)	kW	48	64	80	100	128
Efficiency (DC ÷ AC)	%	> 95				
Permissible range of load power factor		See Diagram				
Output		Triphase + Neutral				
Nominal Output Voltage (selectable)	Vac	380-400-415				
Output Voltage Stability						
- Static (Balanced Load)	%	± 1				
- Static (Unbalanced Load)	%	± 2				
- Dynamic (Step Load 0÷100%÷0)	%	± 5				
- Output Volt. Recovery Time(after step load)	ms	< 20				
- IEC 62040-3		Class 1				
Phase Angle						
- Balanced Load	°	± 1				
- 100% Unbalanced Load		± 1				
Output Frequency	Hz	50 - 60				
Output Frequency Stability						
- Free Running Quartz Oscillator	Hz	± 0,001				
- Inverter Sync. with Mains	Hz	± 2 (other on request)				
- Slew rate	Hz/s	1				
Nominal Output Current (@ 400 Vac output)						
- Cos φ 0,8	A	80	116	145	180	232
- Cos φ 1	A	70	93	115	145	186
Overload Capability		10 min	>100%...125%			
		1 min	>125%...150%			
		10 s	>150%...199%			
		100ms	a 200%			
Short Circuit Current	A	140	186	230	290	290
Short Circuit Characteristic		Elect. short circuit protection, current limited at 2 times nominal current (1,5 times for 160kVA). Automatic stop after 5 seconds				
Selectivity		Within ½ cycle (Fuse gl 20% In)				
Output Waveform		Sinusoidal				
Output Harmonic Distortion						
- Linear Load	%	< 1 %				
- Non Linear Load (Crest factor 3:1)		< 5 %				
- IEC 62040-3		Fully compliant				
Crest Factor (Non linear load)		3 : 1				

Power factor diagram:

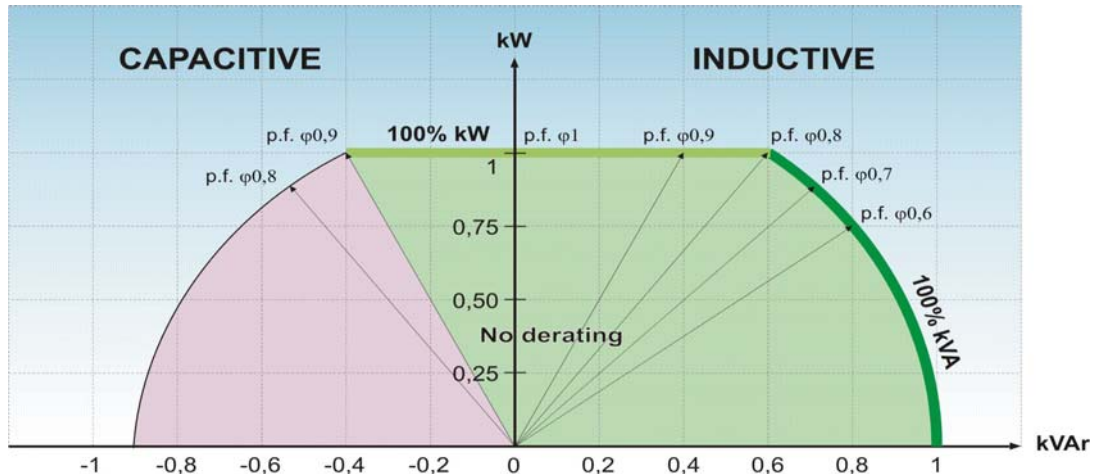

DESCRIPTION:

- The Inverter design is based on a full bridge 6-IGBT matrix, high frequency PWM, fully digitally controlled.
- The output voltage stability and the dynamic response are optimised.
- The selectivity in case of short-circuit is very high and the recovery of the voltage is digitally controlled (Soft Short Recovery Loop “SSRL”).

UPS OUTPUT: BY PASS

Automatic static by-pass		Electronic Thyristor Switch
Protection		Fuses
Bypass	Vac	Triphase + Neutral
Nominal Voltage	Vac	380-400-415
Range	%	±10
Nominal Frequency	Hz	50-60
Range	%	± (1÷5) configurable
Transfer mode		Without break
Transfer inverter → automatic bypass		In case of : - Static Switch test - Inverter test - Inverter not operating - Battery end of discharge
Retransfer Automatic bypass → inverter		- Automatic - Block on bypass after 6 switches within 2 minutes, reset by front panel
Overload Capability	%	-150 Continuously -1000 For 1 Cycle
Manual By-Pass for maintenance		Standard: - Electronically controlled - No break
Back feed protection		Optional

DESCRIPTION:

- The manual by-pass is included as a standard. The electronic control avoids the risks of power interruption in case of transfer from inverter to manual by-pass and vice-versa.
- It is possible to install an external maintenance bypass, with the same functions as the internal one by means of the connection of an external auxiliary signal contact.

PARALLEL

Automatic parallel configuration for redundancy/capacity		Up to 5+1 redundant parallel Up to 6 power parallel by an additional card
Basic parallel configuration		Redundant N+1
Connection type		CAN Bus Loop
Share accuracy (max unbalancement)	%	10
Maximum distance between two Units	m	10 (more on request)
Overload capability		N x 200% for 100 ms N x 125% for 10 min
Automatic by-pass		On each unit
Manual by-pass		On each unit (common as option)

DESCRIPTION:

- The parallel UPS configuration is provided with control for operation both redundant and capacity increasing.
- The parallel control is fully digital and acts on both active and reactive power on each output phase, allowing an accurate load current sharing among the UPSs', even during transient conditions.
- Parallel control is distributed (not centralised control, but on each UPS microcontroller) and communication among units uses CAN BUS connection loop, providing a highly reliable system without "single points of failure".
- Extremely simple parallel control and interconnections make easy installations and on field upgrading, adding new units to the system according to the customer's needs.

MONITORING

LOCAL ON FRONT PANEL

- Synoptic diagram showing: power flow, circuit breaker status and alarms
- LCD display
- Keyboard

PC (Windows OS):

- Connection point-point UPS-PC via RS232
- Remote connection through modem
- All the local indications, alarms and measures
- Basic troubleshooting
- History Events

RELAY CARD

- **SRC card free relay contact**
 - Eight signals Alarms/Statuses are available remote connections:
 - Free relay contact

Relay	Description	Alarms / Status
RL1	Common alarm	A30
RL2	Mains failure	A01
RL3	Battery end of discharge	A09
RL4	Inverter not OK	A13
RL5	Bypass feeding load	A16
RL6	Rectifier OK	S01
RL7	Inverter feeding load	S04
RL8	Bypass OK	S06

REMOTE:

- **SNMP adapter. Optional**
 - LAN, WAN , web server features and monitoring by a browser.
 - UPS operation monitoring and servers management.
- **RS485 interface board. Optional**
 - ModBus protocol
 - UPS operation monitoring
- **Remote Panel. Optional**
 - 4 Alarms/Statuses monitoring and common alarm

OPTIONS

1. BATTERY TEMPERATURE VOLTAGE COMPENSATION
2. INSULATION TRANSFORMER ON BY-PASS
3. VOLTAGE ADAPTATION AUTO-TRANSFORMERS
4. FREE CONTACTS RELAY CARD
5. SERIAL INTERFACE RS-485 (MOD-BUS protocol)
6. SNMP ADAPTER
7. MODEM
8. REMOTE MONITORING PANEL
9. PARALLEL CARD INTERFACE
10. EXTERNAL BATTERY CABINET
11. WALL MOUNTED FUSED SWITCH BOX
12. IN/OUT TOP CABLE ENTRY
13. SPECIAL PAINT